



WILDEN®

AIR OPERATED DOUBLE DIAPHRAGM PUMPS

A **DOVER** RESOURCES COMPANY

T8 Metal Pump

FLOW RATE TO 163 GPM (617.0 LPM)
 MAXIMUM OPERATING PRESSURE = 125 PSI (8.6 BAR)

Specifications

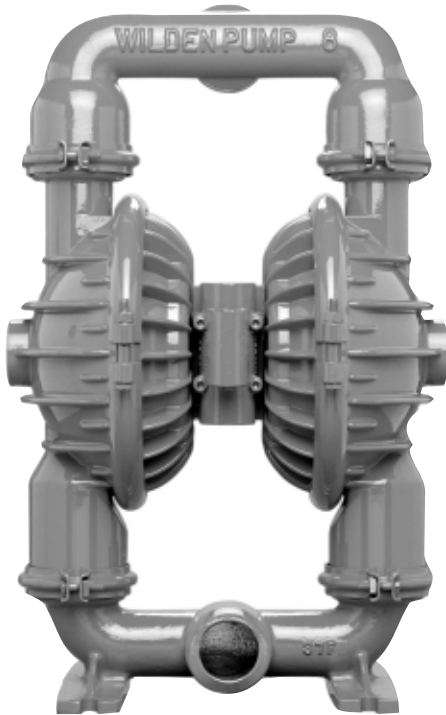

TURBOFLO
 PROGRESSIVE PUMP TECHNOLOGY

WETTED HOUSINGS (Water Chambers and Manifolds)

MATERIAL	SHIP WT.	MATERIAL	SHIP WT.
Aluminum	72 lbs. (33.1 kg.)	Cast Iron	114 lbs. (52.4 kg.)
(OBSOLETE) 316 S.S.	106 lbs. (48.8 kg.)	Hastelloy	116 lbs. (53.4 kg.)

NON-WETTED HOUSINGS

DESCRIPTION	MATERIAL
Center Block	Polypropylene, Aluminum, Nickel-plated Aluminum, or Stainless Steel
Air Valve	Brass, Teflon®-coated Brass, Nickel-plated Brass, or Stainless Steel

MAXIMUM SUCTION LIFT CAPABILITY

DRY LIFT
 21' (6.4 m)
 The above figure represents the rubber-fitted pump capability.

MAXIMUM DIAMETER SOLIDS

1/4" (6.35 mm) Diameter

ELASTOMER OPTIONS

MATERIAL	TEMPERATURE LIMITS	
Polyurethane	+10 (-12.2)	to +150 (65.6) F° (C°)
Neoprene	0 (-17.8)	to +200 (93.3) F° (C°)
Buna-N®	+10 (-12.2)	to +180 (82.2) F° (C°)
Nordel®	-60 (-51.1)	to +280 (137.8) F° (C°)
Viton®	-40 (-40.0)	to +350 (176.7) F° (C°)
Saniflex™	-20 (-28.9)	to +220 (104.4) F° (C°)
Teflon® PTFE	+40 (4.4)	to +220 (104.4) F° (C°)
Wil-Flex™	-40 (-40.0)	to +225 (107.2) F° (C°)

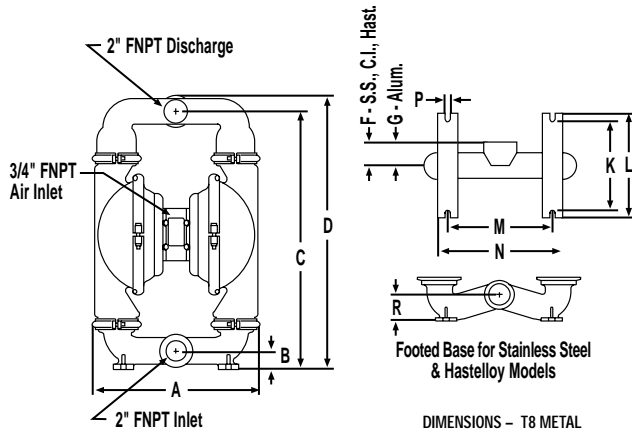

DIMENSIONS - T8 METAL

ITEM	STANDARD (inch)	METRIC (mm)
A	15 29/32	404.0
B	1 7/8	47.6
C	24 3/4	628.7
D	26 11/32	669.2
E	14 9/32	362.7
F	2 1/4	57.2
G	2 7/16	61.7
H	10 21/32	270.7
J	13 1/2	342.9
K	9 1/32	229.4
L	10	254.0
M	10 1/16	255.6
N	12 11/32	313.5
P	9/16	14.3
R	2 1/2	63.5
S	2 1/32	51.6

BSP threads available for liquid inlet and discharge.

Refer to the EOM manual for TPE and Ultra-Flex™ performance curves.

RUBBER-FITTED T8 METAL PUMP

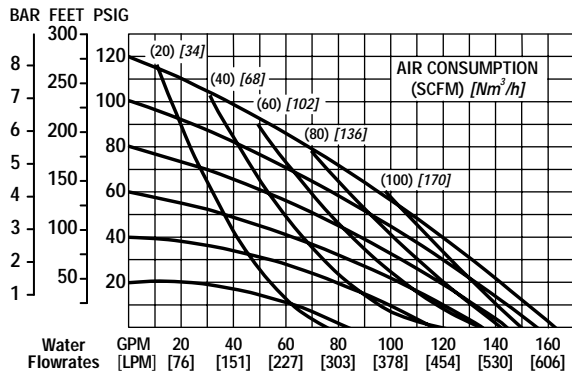

TEFLON®-FITTED T8 METAL PUMP

