

DB Series: Model DB9

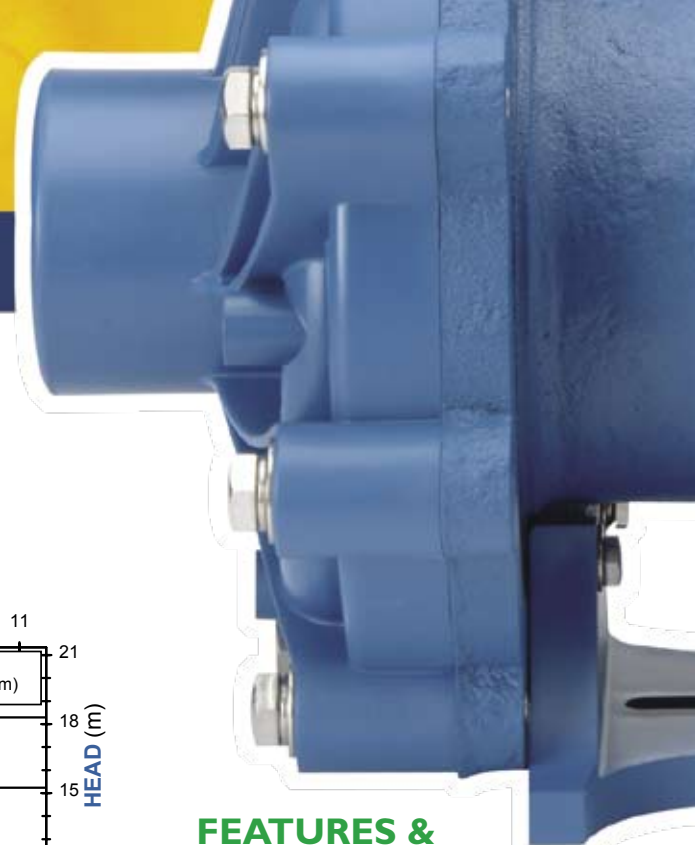

DB9 PERFORMANCE 3450 RPM

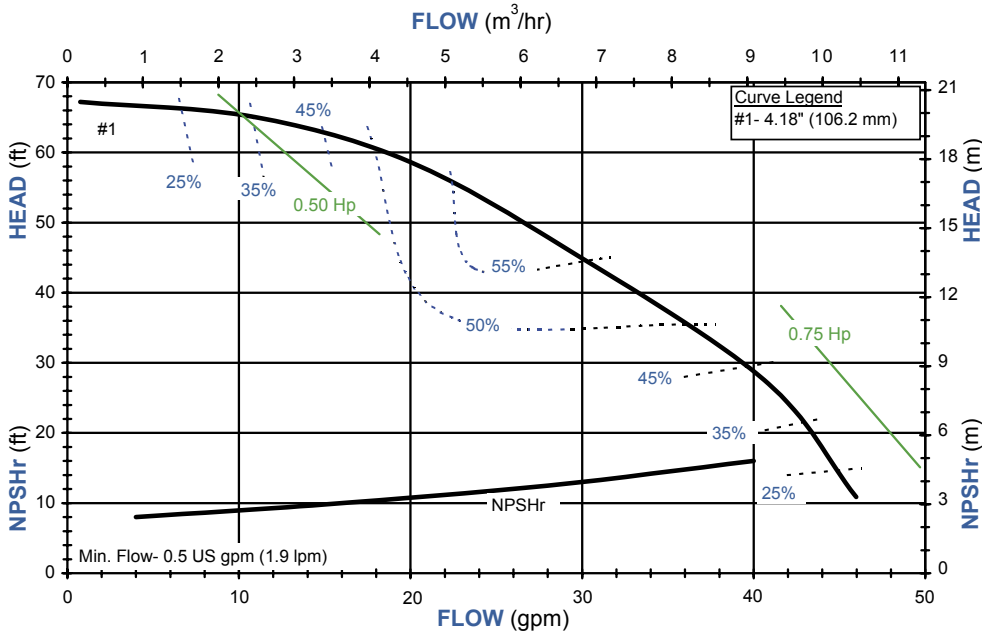

DB9 PERFORMANCE 1725 RPM

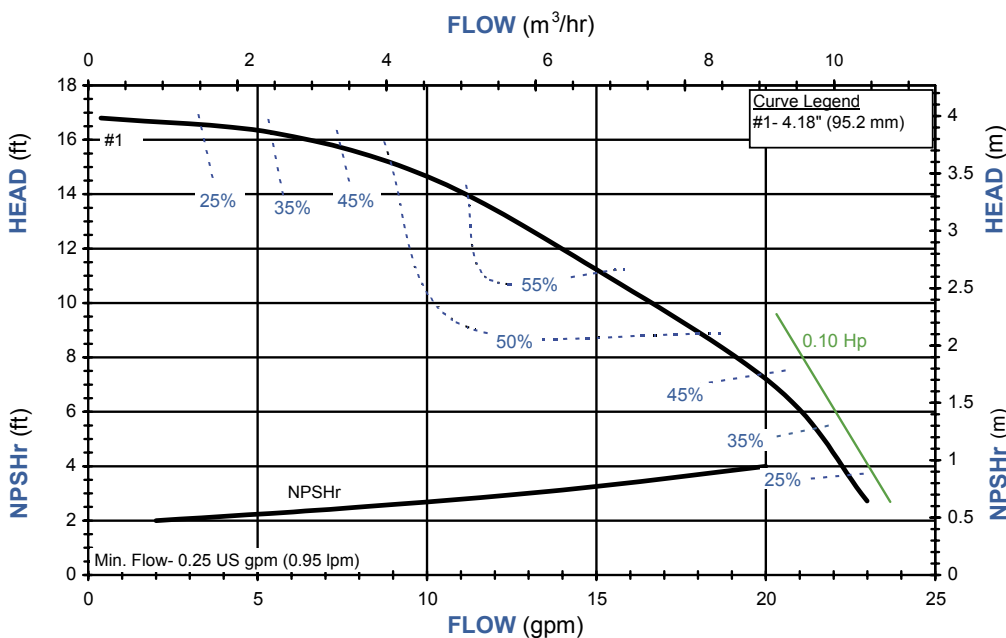

FEATURES & CAPABILITIES

- + Five-year warranty
- + Extended run dry ability (with carbon bushing)
- + High operating efficiency
- + Polypropylene or PVDF construction
- + Powerful neodymium magnets
- + Close-coupled design
- + Threaded (NPT or BSP), flanged, or union connections
- + Horizontal or vertical installation with IEC motor
- + Back pullout design
- + Mounts to NEMA and (B5 & B14) IEC motor frames
- + Easy set measurement free drive
- + ISO 1940 G2.5 balancing
- + CE certified/ATEX available
- + Working pressure to 80 psi (5.5 bar)
- + Specific gravity over 1.8
- + Viscosity up to 150 cP
- + Polypropylene—180° F (82° C)
- + PVDF—220° F (104° C)

APPLICATIONS

- + Chemical processing
- + Plating
- + Water and wastewater
- + Electronics
- + Pharmaceuticals
- + Wet scrubber
- + Pulp and paper
- + Heat exchanger
- + and many more!

1	Impeller housing	Glass-fiber reinforced polypropylene	Carbon-fiber reinforced PVDF
1A	Impeller housing thrust ring options	High-purity alumina ceramic, silicon carbide	
2	O-ring options	FKM, EPDM, Simriz®, Kalrez®	
3	Impeller	Glass-fiber reinforced polypropylene	Carbon-fiber reinforced PVDF
3A	Impeller thrust ring options	Glass-fiber molybdenum disulfide filled PTFE, silicon carbide	
4	Inner drive	Neodymium iron boron magnets encapsulated in unfilled polypropylene	Neodymium iron boron magnets encapsulated in unfilled PVDF
5	Bushing options	Carbon, PTFE, high-purity alumina ceramic, silicon carbide	
6	Shaft options	High-purity alumina ceramic, Hastelloy® C, silicon carbide	
7	Barrier	Glass-fiber reinforced polypropylene	Carbon-fiber reinforced PVDF
7A	Barrier thrust ring	High-purity alumina ceramic	
8	Clamp ring	Ductile iron	
9	Motor adapter	Glass-fiber reinforced polypropylene	
10	Outer drive magnet	Nickel plated neodymium iron boron magnets/steel	
11A	Motor adapter sealing option	Buna N (STD), FKM, EPDM	
11B	sealing option		
11C	(NEMA only)		

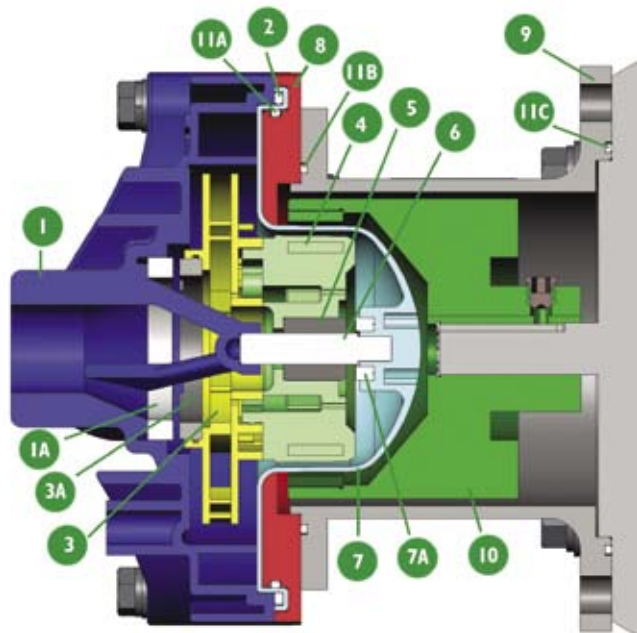

Kalrez® is a registered trademark of DuPont Performance Elastomers
 Simriz® Perfluoroelastomer is a registered trademark of the Simrit®
 division of Freudenberg-NOK
 Hastelloy® C is a registered trademark of Haynes International, Inc.

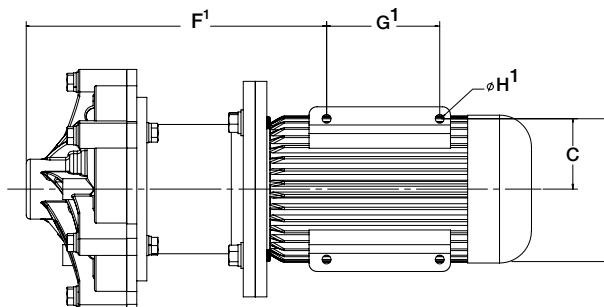
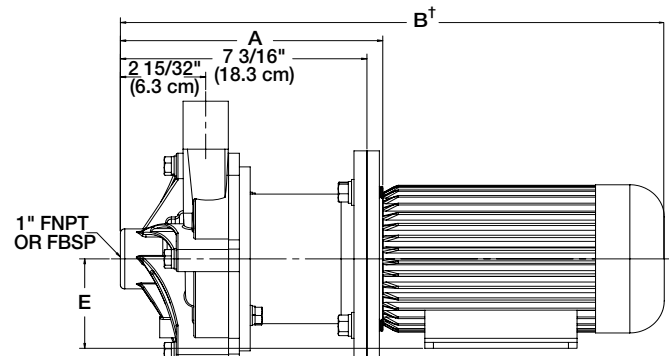
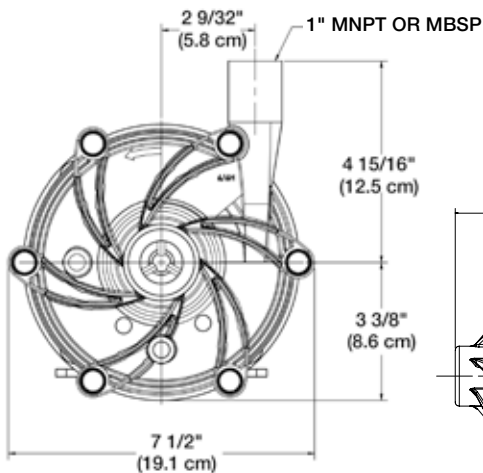

¹ Dimensions for F, G, and H can be found in the Outline Dimensions booklet in the Downloads section of www.finishthompson.com.

Motor Frame	A	B [†]	C	D	E	Weight - lbs. [kg]	
						PP	PVDF
NEMA 56C	7-3/16" [18.3 cm]	17-7/16" [44.3 cm]	2-7/16" [6.2 cm]	4-7/8" [12.4 cm]	3-1/2" [8.9 cm]	10.5 [4.8]	11.1 [5.0]
NEMA 145TC	7-3/16" [18.3 cm]	17 15/16" [45.6 cm]	2-3/4" [7.0 cm]	5-1/2" [14.0 cm]	3-1/2" [8.9 cm]	10.5 [4.8]	11.1 [5.0]
IEC 63 w/B14 or B5* flange	7-5/8" [19.4 cm]	14-7/8" [37.8 cm]	1-31/32" [5.0 cm]	3-15/16" [10.0 cm]	2-15/32" [6.3 cm]	14 [6.4]	15 [6.8]
IEC 71 w/B14 or B5* flange	7-5/8" [19.4 cm]	15-13/16" [40.2 cm]	2-7/32" [5.6 cm]	4-13/32" [11.2 cm]	2-25/32" [7.1 cm]	14 [6.4]	15 [6.8]

Dimensions and weights are for reference only.
[†]Varies with motor manufacturer.

Note: Above listed weights are for pumps only. Motor weights not included.

